

## INSTALLATION GUIDE FOR ADDINGTON II TYPE 10 – 20 RADIATOR



### PLEASE READ THIS INSTRUCTION THOROUGHLY BEFORE STARTING THE INSTALLATION

- The product that you are about to install should only be used in DOMESTIC CENTRAL HEATING systems unless the size you purchased is compatible with element for electric only usage. Please consult your engineer or supplier.
- Max. Working pressure : 4 bar
- Please note that Type 10 & 20 – 500mm and 600mm height radiator DO NOT come with Pre-Fitted flow diverters and won't require flow diverters.
- Our products are designed to be fitted by a fully qualified installer and in compliance with all relevant regulations.
- Eastbrook will not accept any liability for damage, injury or unsatisfactory performance if the product is not fitted by a fully qualified installer.
- We reserve to change any technical specification without prior notice.
- This product is warrantied against manufacturing defects and our liability under any guarantee is limited to repair or replacement of the defective product. The warranty is not transferrable.
- Corrosion inhibitor\* must be added to the system regularly in order to maintain the warranty. \* See last page for more details.

### BEFORE STARTING

- Make sure that the installation kit includes followings ;



- Blind Plug - 1 pc
- Air Vent - 1 pcs
- Wall Brackets - 4 pcs
- Wall Plug 6.5 x 50mm - 8 pcs
- Screw - 8 pcs
- Bracket Buffer - 4 pcs

\* Please use a 10mm drill bit for the wall plugs.

- Make sure that the wall is strong enough to hold the weight of the product that is filled with water.
  - If the wall is plasterboard or stud wall, please replace wall plugs with the appropriate wall fixings.
- If your product is larger than 292 x 588mm. , we strongly recommend to have a help in lifting to avoid injuries.
- If your product is Type10 or Type20 (**excluding 500&600mm height**), please pay extra attention that it is supplied with PRE-INSTALLED FLOW DIVERTER, that is marked with white sticker on the header of the product. If white sticker is removed check with your supplier.
- Radiator valves are not supplied with the Radiators.
- Please ensure that you wear all necessary protective equipment.

# INSTALLATION GUIDE

**PLEASE READ THIS INSTRUCTION THOROUGHLY BEFORE STARTING THE INSTALLATION**



## TYPE 10 PRE-INSTALLED FLOW DIVERTER (excluding 500&600mm height)

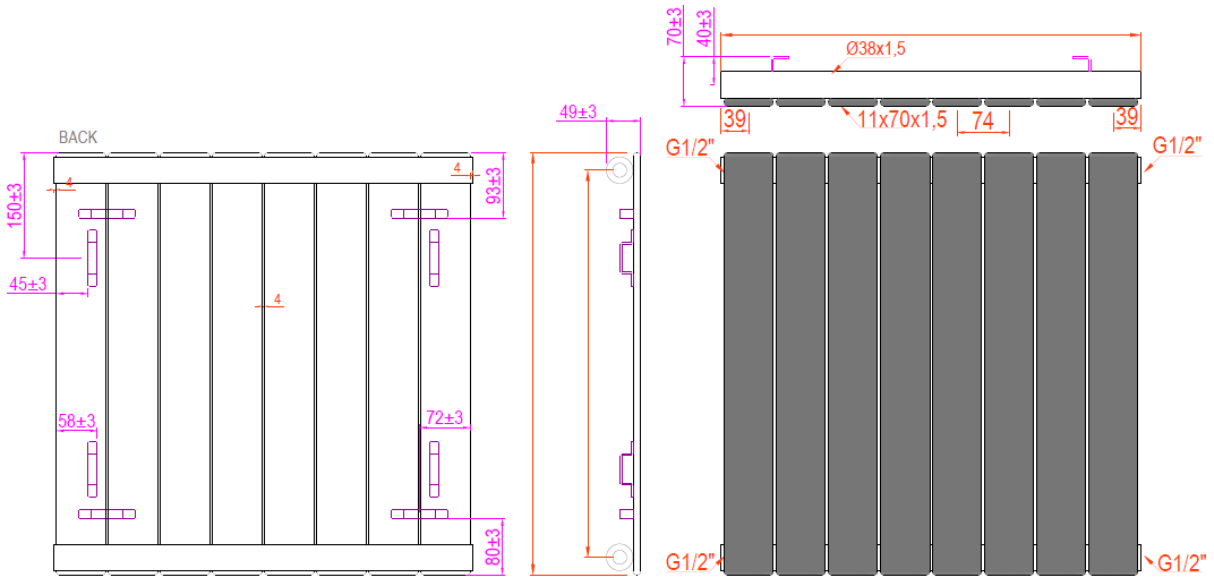

## TYPE 20 PRE-INSTALLED FLOW DIVERTER (excluding 500&600mm height)

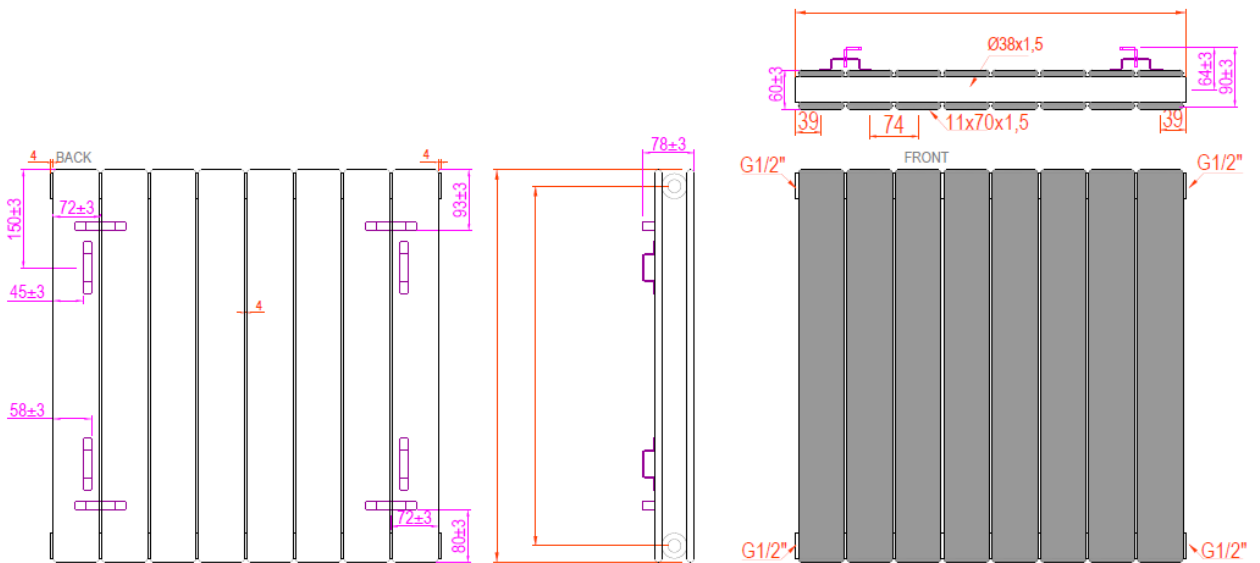

Horizontal Installation



Vertical Installation

- Please note that Type 10 and 20 radiators can be fitted **vertically** OR **horizontally** thanks to the bracket holders located at the back of the radiator..

# INSTALLATION GUIDE

## PLEASE READ THIS INSTRUCTION THOROUGHLY BEFORE STARTING THE INSTALLATION

- Screw the Blind Plug and Air Vent firmly. Ensure air vent is fitted to top opposite corner to the flow.
- Position the radiator to line up with the supply and return pipe.
- Position the brackets on the wall that line up with the centerline of the brackets on the Radiator.
  - Before drilling the wall check for pipes and wires.
- Mount the brackets to allow the radiator min. 150 mm above the finished floor level.
- Fix the brackets firmly to the wall using appropriate hardware.
- Place the bracket's buffer into the slots on the wall bracket.
- Lift the radiator into position on the wall brackets. If necessary; have help in lifting to avoid injuries. ⚠
- Type 10 & 20 (**excluding 500 & 600mm height**) have pre-installed flow diverter for which the location is marked with White Sticker. White sticker must be at the bottom.

⚠ If Type 10 and/or 20 will be fitted **Vertically** , **DO NOT** break the diverter. Leave it on and connect the valves on the header (collector).

⚠ If the Type 10 and/or 20 will be fitted **Horizontally** ; in order to allow the water circulation the diverter **MUST** be broken by the help of screwdriver an/or a thin metal bar.

⚠ For Electric & Dual Fuel installations, the diverter **MUST** be broken by the help of screwdriver an/or a thin metal bar.

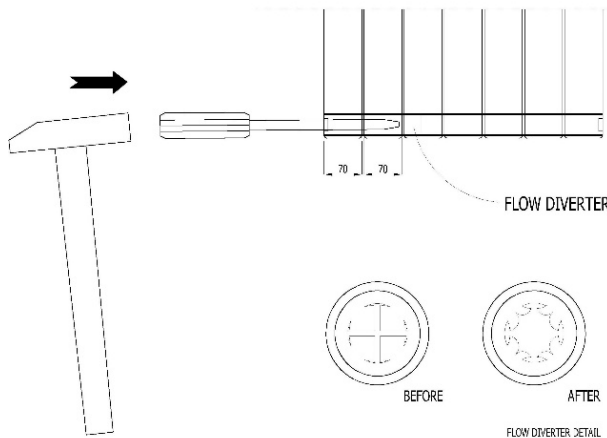

Gently insert the screwdriver / thin metal bar into the inlet from the close end of the sticker for about 150 mm and notice the diverter and apply force to break the flow diverter.

- Connect the radiator valves (not supplied with the products) and fill the system to check for any leakage, fix as necessary.
- Run the system up to full temperature and release any trapped air using the Air Vent Plug.
- Installation is completed.
- Make sure that the CORROSION INHIBITOR is added in the system and regularly maintained for warranty.
- Please ensure, when adding inhibitor, not to underdose or overdose and follow the inhibitor instructions. The Ph level of the system water should be between 6.5 and 7.5  
If the system water is too acidic then the metals in the system would corrode. If the system water is too alkaline, then there is a higher risk of electrolysis.
- From time to time, it is advisable to clean your radiator with a warm damp cloth. Never use any form of abrasive cleaner or chemical.

**Technical Helpline Mon – Fri / 8am - 5pm**

**Helpline Phone : 01452 317890**

**Helpline email : [technical@eastbrookco.com](mailto:technical@eastbrookco.com)**

## CONGRATULATIONS

You are the proud owner of an exclusive Addington II Radiator/Towel Rail which has been specially produced by our craftsmen who would wish you to enjoy many years of satisfaction from it.

## INSTALLATION

This product must be installed by a fully qualified engineer.

- Please consider using an Eastbrook Valve Set – this will ensure that your radiator looks its best with matching radiator valves.
- On commissioning, flush the central heating system thoroughly using a proprietary solution to ensure that aggressive substances such as fluxes and manufacturing residue, from which internal surfaces of your radiator can sustain irreparable damage – are removed. A specifically approved inhibitor for aluminium radiators needs to be subsequently added to the heating system in order to protect the radiator and other parts of the central heating system to promote extended operating lifespan.

Please ensure, when adding inhibitor, not to underdose or overdose and follow the inhibitor instructions. The Ph level of the system water should be between 6.5 and 7.5

The inhibitor must not be nitrate based!

Do not use softened water in your radiator!

Beware of own brand inhibitors!

Eastbrook recommends FERNOX F1 or equivalent inhibitor for your radiators.

## MAINTENANCE

- From time to time, it is advisable to clean your towel rail with a warm damp cloth. Never use any form of abrasive cleaner or chemical.
- Corrosion inhibitor must also be regularly maintained, please consult your engineer for details.

## IMPORTANT

- Maximum working pressure of this radiator is 4 bar.
- This radiator is to be used on Domestic Central Heating systems only. (Not suitable for use on direct hot water systems). Please consult your engineer or supplier.

## WARRANTY

Your Addington II Radiator/Towel Rail is fully warranted for **five years** in respect of defective materials and workmanship and subject to installation being carried out by a qualified engineer in accordance with good practice and corrosion inhibitors being regularly maintained.

**REMEMBER** ..... Excellence is worth looking after.

**HELPLINE Phone : 01452 317890**

**HELPLINE email : [technical@eastbrookco.com](mailto:technical@eastbrookco.com)**